

REV. NO.	REVISED	DATE	DRAWN	CHECKED	APPROVED
0	NEW DRAW	02.04.13	WU, KIM		
△	TALL (38.0 → 43.0)	02.04.19	WU, KIM		

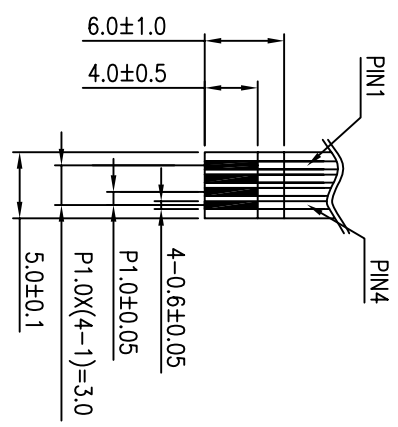
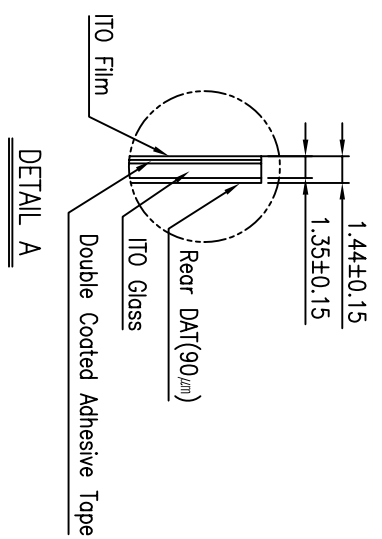
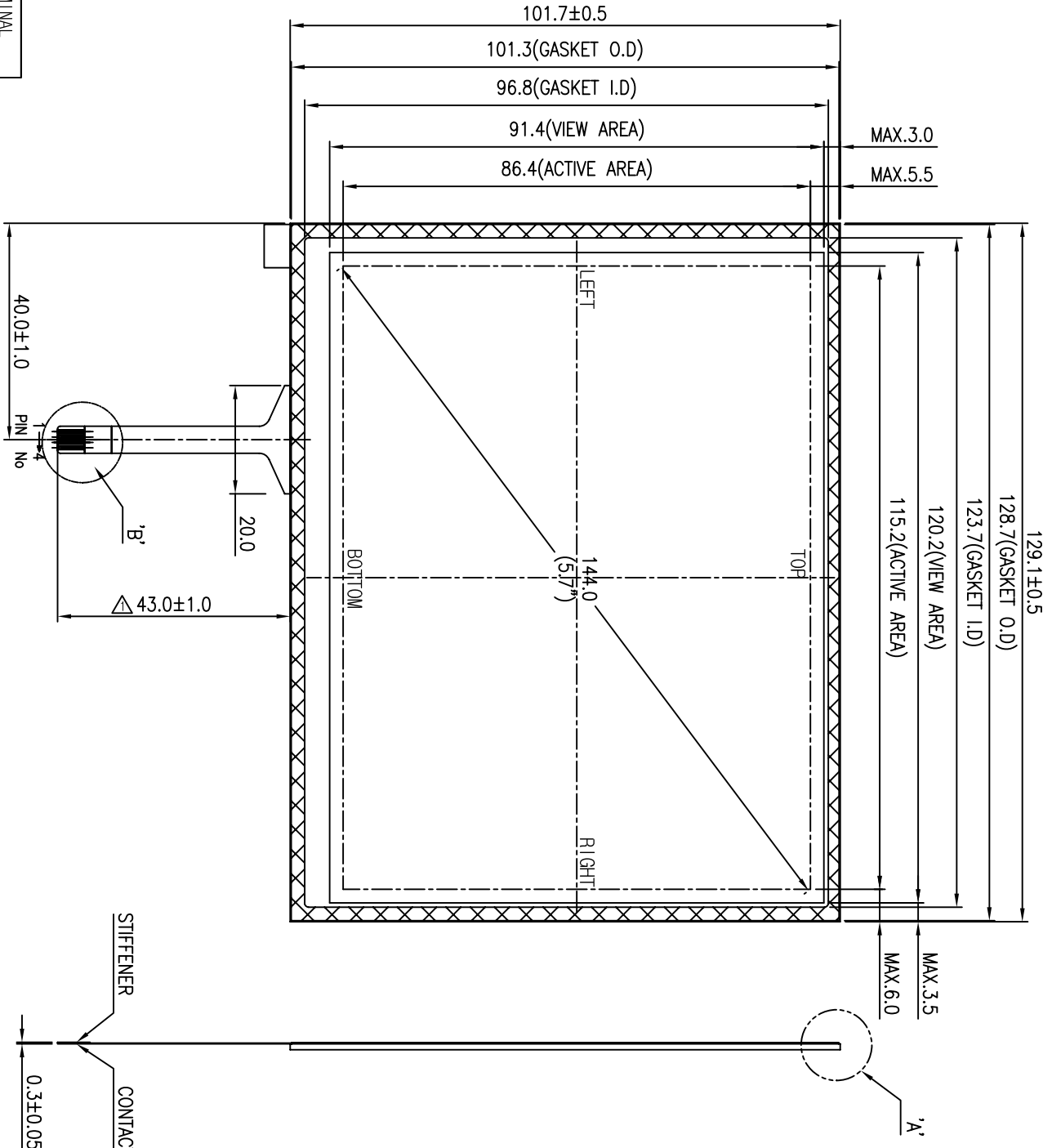

- NOTE**
- 1) TYPE : NON-GLARE TYPE
 - 2) GLASS THICKNESS : 1.1t
 - 3) CONNECTOR : FPC
 - 4) GENERAL TOLERANCE : ±0.5

NO	SYMBOL	TERMINAL
1	TOP	TOP
2	LEFT	LEFT
3	BOTTOM	BOTTOM
4	RIGHT	RIGHT

5.7" TOUCH PANEL

SCALE : NONE

APPROVE	UNIT	PROJECTION	DRAWING NO.	REV.
CHECK	SCALE	NO. OF	HT057A-NDJHG45-R	
DESIGN				
DRAW				

Hot touch.com

DESCRIPTION: 5.7" TOUCH PANEL

SHEET: 1/1