

PCI-compliant
2 port Isolated RS-232C

COM-2CL-PCI



PCI-compliant
4 port Isolated RS-232C

COM-4CL-PCI



These PCI boards were designed for extending RS-232C compatible serial communication functionality on your PC. COM-2CL-PCI has two RS-232C communication ports. COM-4CL-PCI has four RS-232C communication ports. With a 64byte built-in FIFO buffer for transmission and reception of each channel, the product supports a baud rate of up to 230,400bps. It also comes with a Windows® driver, which allows boards to be used as standard COM ports.

Packing List

- Board (One of the followings) ...1
[COM-2CL-PCI, COM-4CL-PCI]
 - First step guide ...1
 - COM Setup Disk (CD-ROM *1) ...1
 - Distribution cable (0.25m) ...1 (For COM-4CL-PCI only)
- *1: The CD-ROM contains the driver software and User's Guide.

Features

- 230,400bps (max) RS-232C Serial Communication

COM-2CL-PCI – two RS-232C-compliant serial ports.
COM-4CL-PCI – four RS-232C-compliant serial ports.
Baud rates from 15 to 230,400 bps – user selectable.

- Boards can be used as standard serial ports when operating in a Windows® environment

These products come with a driver library that allows the boards to be used under Windows® in the same way as COM ports on a PC. Under Windows®, these boards support the OS-standard Win32 API communication function as well as Visual Basic MSComm. The driver library also includes a diagnostic program to confirm hardware operation and to perform communication tests.

- 16 boards (max) can be installed with an access range from COM1 to COM256.

Up to 16 boards can be installed in a single PC.
COM1 - COM256 can be set using the device manager.

- Each channel is equipped with separate 64-byte FIFO buffers for transmit and receive.

Each individual channel has FIFO buffer memory (transmission: 64 bytes, reception: 64 bytes).
This feature is useful for high speed communications and to reduce the load to the CPU during transmitting/receiving.

- COM-2CL-PCI uses the same standard 9-pin D-SUB connectors that are used on a PC.

This board has a general-purpose RS-232C 9-pin D-SUB connector, allowing you to use standard commercial RS-232C cables.

- Available cables and connectors [optional].

COM-2CL-PCI: Straight cables (1.8m), cross cables (1.8m) and 9-pin D-SUB connectors (both male and female) for creating your own cables.

COM-4CL-PCI: 4 channel distribution cable and 37-pin D-SUB connectors (male) for creating your own cables.

- The RS-232C signals can be controlled and monitored via software.

The RTS, CTS, DTR and DSR signals can be controlled and monitored using your software application.

Specifications

COM-2CL-PCI

Item	Specification
Number of channels	2channels
Interface type	RS-232C
Transfer method	Asynchronous serial transfer
Baud rate	15 - 230,400bps *1 *2
Data length	5, 6, 7, 8 bits 1, 1.5, 2 stop bits *1
Parity check	Even, Odd, Non-parity *1
Controller chip	162850 or equivalent (Each channel has 64-byte receive and 64-byte transmit FIFO buffers.)
Connecting distance	15m (Typical)
Interrupt requests	1 level use *3
Memory address	1024byte boundary
Power consumption (max)	5VDC 100mA
Operating environment	0 - 50°C, 10 - 90%RH (No condensation)
Bus specification	PCI (32bit, 33MHz *4)
Dimensions (mm)	121.69(L) x 88.0(H)
Connector used	9-pin D-SUB connector, 2031-2-9-P [mfd. by gallant, M(male) type] equivalent
Weight	100g

*1: These items can be set by software.

*2: Data transmission at high speed may not be performed normally depending on the environment including the status of external device and cable length.

*3: The interrupt signals from individual channels are arranged into a single interrupt signal and output.

*4: This board requires power supply at +5V from an expansion slot (it does not work on a machine with a +3.3V power supply alone).

COM-4CL-PCI

Item	Specification
Number of channels	4channels
Interface type	RS-232C
Transfer method	Asynchronous serial transfer
Baud rate	15 - 230,400bps *1 *2
Data length	5, 6, 7, 8 bits 1, 1.5, 2 stop bits *1
Parity check	Even, Odd, Non-parity *1
Controller chip	162850 or equivalent (Each channel has 64-byte receive and 64-byte transmit FIFO buffers.)
Wiring distance	15m (Typ.)
Interrupt requests	1 level use *3
Memory address	1024byte boundary
Power consumption (Max.)	5VDC 120mA
Operating temperature	0 - 50°C, 10 - 90%RH (No condensation)
Bus specification	PCI (32bit, 33MHz *4)
Dimension (mm)	121.69(l) x 88.0(h) [4.79" x 3.46"]
Connector used	37-pin D-SUB connector, 2031-2-37-S [mfd. by Gallant, (female)] or equivalent
Weight	130g [4.59oz]

*1: These items can be set via software.

*2: High speed data transmission is dependent upon the application environment including external device status and wiring distance.

*3: Individual channel interrupt signals are arranged into a single interrupt signal before output.

*4: This board requires +5V power from the expansion slot (it will not work on a system that only supplies +3.3V).

Support Software

We recommended that you use CONTEC support software in your application and development environment.

Standard COM Driver Software "COM Setup Disk" (Included)

The purpose of this software is to allow the CONTEC serial communication boards to be used under Windows® in the same manner as standard computer COM ports. By installing additional boards, you can use COM ports in the range COM1 - COM256.

The boards can be used for all types of serial communications including remote access service (RAS) and uninterruptible power supply (UPS) applications.

Under Windows®, the serial ports can be accessed using the standard Win32 API communication routines (CreateFile(), WriteFile(), ReadFile(), and SetCommState(), etc.) The serial ports are also compatible with Visual Basic communication control (MSComm).

Operating environment

Operating Systems: Windows® Vista®, XP®, Server 2003®, 2000®
You can download the latest software versions from CONTEC's document site (<http://www.contec.com/comdrv/>).

For more details on supported operating systems, applicable languages and new information, please visit CONTEC's Web site.

Physical Dimensions

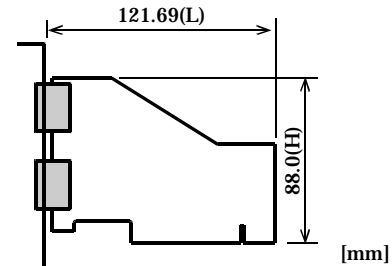

The standard outside dimension (L) is the distance from the end of the board to the outer surface of the slot cover.

Optional Cables, Connectors and Accessories

Cables & Connectors

- RS-232C Straight Cable – 9pin D-SUB (1.8m) :RSS-9M/F
- RS-232C Cross Cable – 9pin D-SUB (1.8m) :RSC-9F
- RS-232C Straight Cable – 25pin D-SUB (1.8m) :RSS-25M/F
- RS-232C Cross Cable – 25pin D-SUB (1.8m) :RSC-25F
- RS-232C Connection Conversion Straight Cable – 25pin M to 9pin F (1.8m) :RSS-25M/9F
- RS-232C Connection Conversion Straight Cable – 25pin F to 9pin M (1.8m) :RSS-25F/9M
- RS-232C Connection Conversion Cross Cable – 25pin F to 9pin F (1.8m) :RSC-25F/9F
- Connection Conversion Cable – 37pin M → 4x 9pin M (250mm) :PCE37/9PS
- Connection Conversion Cable – 37pin M → 4x 25pin M (250mm) :PCE37/25PS
- COM-4ch Board Optional Cable for CCU – 78pin F to 25pin M (2m) :RSS-78M/37M
- Set of five 9pin D-SUB (male) connectors :CN5-D9M
- Set of five 9pin D-SUB (female) connectors :CN5-D9F
- Set of five 37pin D-SUB (male) connectors :CN5-D37M

Accessories

- Connection Conversion Unit for RS-232C – 78pin F → 8x 25pin M :CCU-78F/25M *1

*1: RSS-78M/37M cable is needed when using this unit.

*Check CONTEC's Web site for additional information on these options.

Connection to External Devices

In addition to connecting directly to the board's connector, you can also connect external devices via a connection distribution cable or connection distribution unit.

- Connecting directly to the port connector
- Using a connection distribution cable :COM-4CL-PCI
- Using a connection distribution unit :COM-4CL-PCI

COM-2CL-PCI

Connecting directly to the port connector
If you are connecting an external device directly with the connector on the board, use one of the optional RS-232C cables. If you make your own cables, use a CN5-D9F or equivalent connector.

Pin Assignment

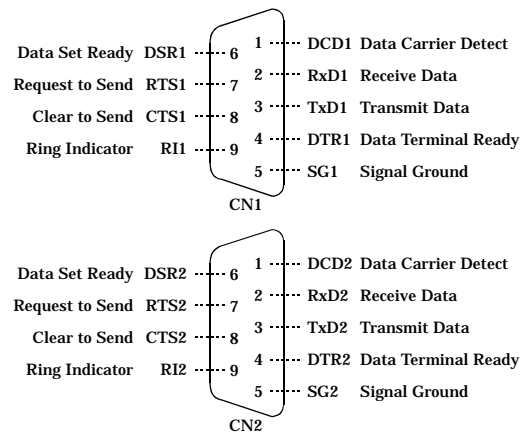
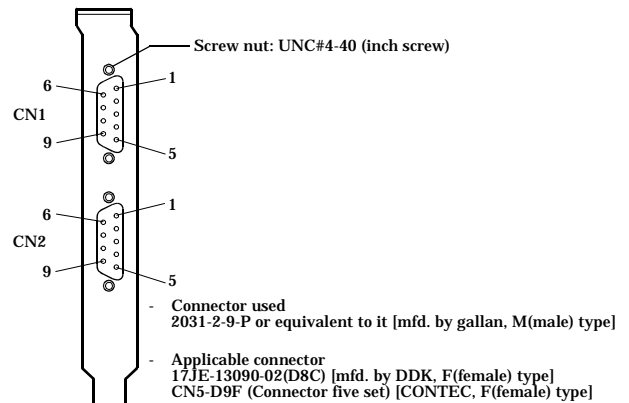

Cable (Option)

- RS-232C Straight Cable – 9pin D-SUB (1.8m) :RSS-9M/F
- RS-232C Cross Cable – 9pin D-SUB (1.8m) :RSC-9F

COM-4CL-PCI

When using a COM-4CL-PCI, an alternative to connecting an external device directly to the connector on the board is to use either a connection conversion cable or connection conversion unit.

Using a 9-pin D-SUB Connector Distribution Cable

Use the bundled distribution cable or CONTEC's PCE37/9PS (available separately) to distribute the signal through four 9-pin D-SUB male connectors.

Use commercially available 9-pin D-SUB cables to connect from the four individual connectors to external devices.

Pin assignment

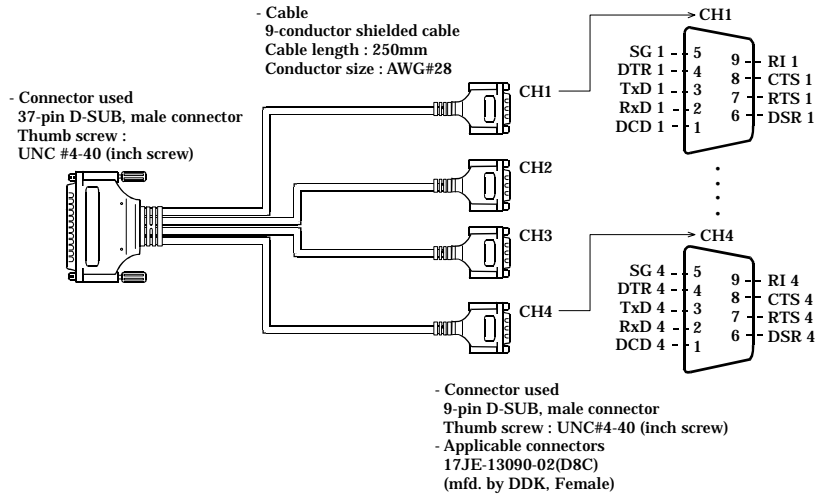

Connection distribution cable (Optional)

Connection Conversion Cable - 37pin M → 4x 9pin M (250mm) :PCE37/9PS

Cable (Optional)

RS-232C Straight Cable with 9pin D-SUB (1.8m) :RSS-9M/F
RS-232C Cross Cable with 9pin D-SUB (1.8m) :RSC-9F

Using a 25-pin D-SUB Connector Distribution Cable

Use CONTEC's PCE37/25PS connection distribution cable (available separately) to distribute the signal through four 25-pin D-SUB male connectors.

Use CONTEC's 25-pin D-SUB cables (or equivalent) to connect from the four individual connectors to external devices.

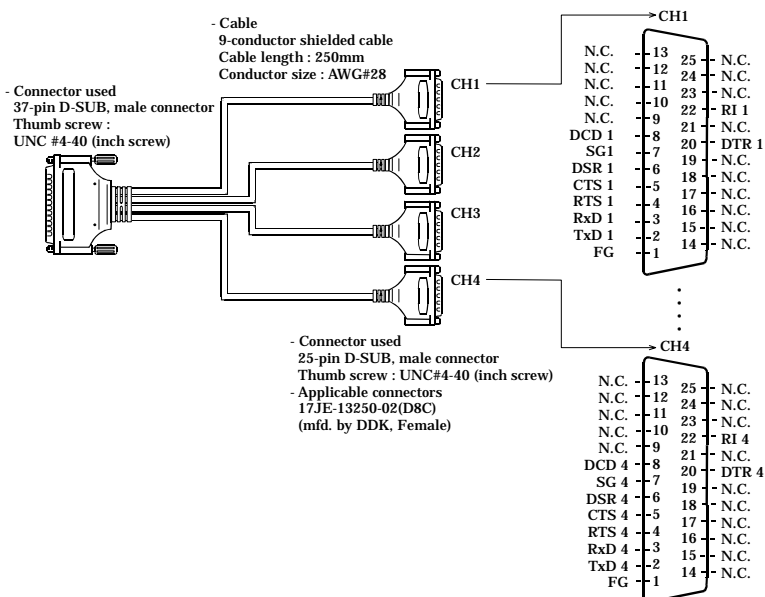

Connection distribution cable (Optional)

Connection Conversion Cable – 37pin M → 4x 25pin M (250mm) :PCE37/25PS

Cables (Optional)

RS-232C Straight Cable – 25pin D-SUB (1.8m) :RSS-25M/F
RS-232C Cross Cable – 25-pin D-SUB (1.8m) :RSC-25F
RS-232C Connection Conversion Straight Cable – 25pin F→ 9pin M (1.8m) :RSS-25F/9M
RS-232C Connection Conversion Cross Cable – 25pin F→ 9pin F (1.8m) :RSC-25F/9F

Using a 25-pin D-SUB Connector Distribution Unit

Use CONTEC's CCU-78F/25M connection distribution unit (available separately) to distribute the signal through four 25-pin D-SUB male connectors.

Features:

- Unit is DIN rail mountable when using CONTEC's ADP-1 DIN rail adapter (available separately).
- Unit can be mounted on a wall or panel.
- By connecting to an external power supply, the unit can provide power through the 25-pin D-SUB connector(s).

Use CONTEC's 25-pin D-SUB cables (or equivalent) to connect from the four individual connectors to external devices.

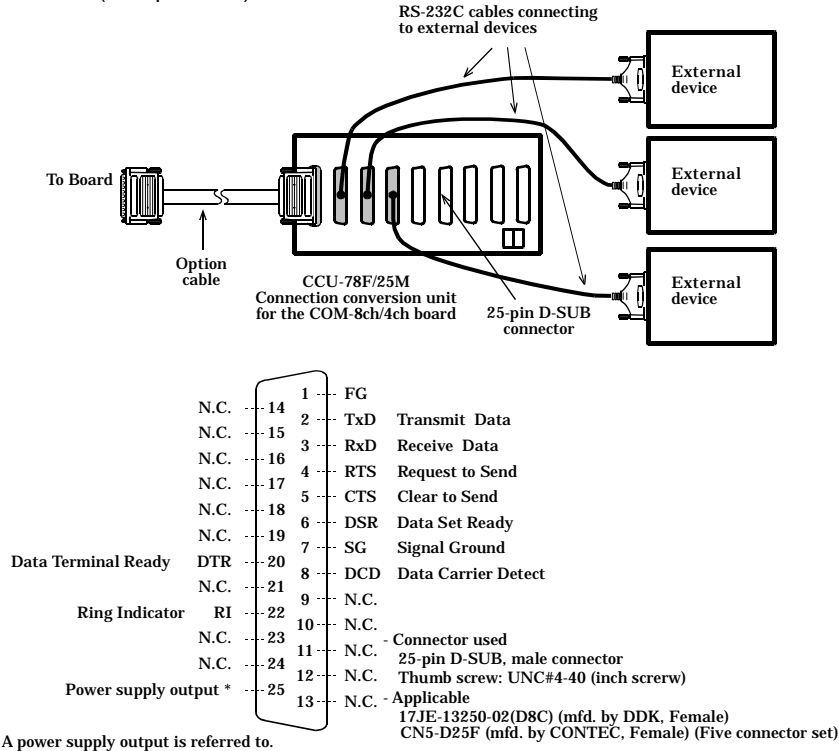

Connection distribution cable & connection distribution unit (Optional)

Connection Conversion Unit for RS-232C – 78pin F→ 8x 25pin M :CCU-78F/25M
4ch Connection Cable for CCU-78F/25M (2m) :RSS-78M/37M

Connection cable (Optional)

RS-232C Straight Cable – 25pin D-SUB (1.8m) :RSS-25M/F
RS-232C Cross Cable – 25pin D-SUB (1.8m) :RSC-25F
RS-232C Connection Conversion Straight Cable – 25pin F→ 9pin M (1.8m) :RSS-25F/9M
RS-232C Connection Conversion Cross Cable – 25pin F→ 9pin F (1.8m) :RSC-25F/9F

Connecting directly to the port connector

When connecting an external device directly from the connector on the board, use a CN5-D9F or equivalent connector.

Pin Assignment

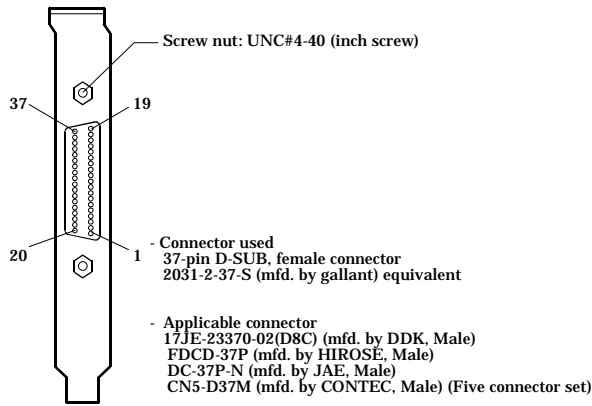

CH1 Receive Data 1	RxD1	37	19	TxD1	CH1 Transmit Data 1
CH1 Clear to Send 1	CTS1	36	18	RTS1	CH1 Request to Send 1
CH1 Signal Ground 1	SG1	35	17	DSR1	CH1 Data Set Ready 1
CH1 Data Carrier Detect 1	DCD1	34	16	DTR1	CH1 Data Terminal Ready 1
CH2 Transmit Data 2	TxD2	33	15	RI1	CH1 Ring Indicator 1
CH2 Request to Send 2	RTS2	32	14	RxD2	CH2 Receive Data 2
CH2 Data Set Ready 2	DSR2	31	13	CTS2	CH2 Clear to Send 2
CH2 Data Terminal Ready 2	DTR2	30	12	SG2	CH2 Signal Ground 2
CH2 Ring Indicator 2	RI2	29	11	DCD2	CH2 Data Carrier Detect 2
CH4 Receive Data 4	RxD4	28	10	TxD4	CH4 Transmit Data 4
CH4 Clear to Send 4	CTS4	27	9	RTS4	CH4 Request to Send 4
CH4 Signal Ground 4	SG4	26	8	DSR4	CH4 Data Set Ready 4
CH4 Data Carrier Detect 4	DCD4	25	7	DTR4	CH4 Data Terminal Ready 4
CH3 Transmit Data 3	TxD3	24	6	RI4	CH4 Ring Indicator 4
CH3 Request to Send 3	RTS3	23	5	RxD3	CH3 Receive Data 3
CH3 Data Set Ready 3	DSR3	22	4	CTS3	CH3 Clear to Send 3
CH3 Data Terminal Ready 3	DTR3	21	3	SG3	CH3 Signal Ground 3
CH3 Ring Indicator 3	RI3	20	2	DCD3	CH3 Data Carrier Detect 3
			1	N.C.	

CN1

Types of Cables and Connection Examples

RS232C interface cables differ with each connecting device. Please use straight or cross (reverse) type cables depending upon the specifications of the external devices.

Example 1

Connection to a Modem (straight cable)

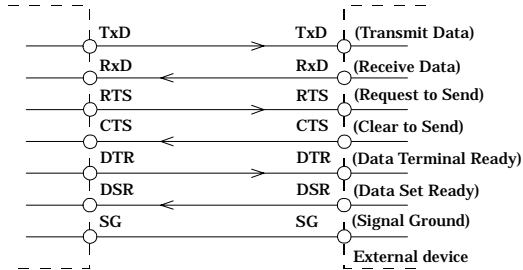

Example 2

Connection to a Computer (cross cable)

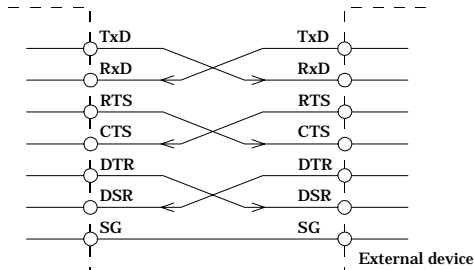

Example 3

Connection to an External Device

